

# NATIONAL SERVICE TECHNICIAN'S GUIDE

\$5.50

	TONE GROUP 1		TONE GROUP 2		TONE GROUP 3		TONE GROUP 4		TONE GROUP 5		TONE GROUP 6		
	CODE	FREQ. (HZ)	CODE	FREQ. (HZ)	CODE	FREQ. (HZ)	CODE	FREQ. (HZ)	CODE	FREQ. (HZ)	CODE	FREQ. (HZ)	
PAGER CODE DIGIT	1	111	3490	121	600.9	138	288.5	141	339.6	151	584.8	191	1153.4
	2	112	368.5	122	634.5	108	296.5	142	358.6	152	617.4	192	1185.2
	3	113	389.0	123	669.9	139	304.7	143	378.6	153	651.9	193	1217.8
	4	114	410.8	124	707.3	109	313.0	144	399.8	154	688.3	194	1251.4
	5	115	433.7	125	746.8	160	953.7	145	422.1	155	726.8	195	1285.8
	6	116	457.9	126	788.5	130	979.9	146	445.7	156	767.4	196	1321.2
	7	117	483.5	127	832.5	161	1006.9	147	470.5	157	810.2	197	1357.6
	8	118	510.5	128	879.0	131	1034.7	148	496.8	158	855.5	198	1395.0
	9	119	539.0	129	928.1	162	1063.2	149	524.6	159	903.2	199	1433.4
	0	110	330.5	120	569.1	189	1092.4	140	321.7	150	553.9	190	1122.5

## Paging Products - Code Plan Guide

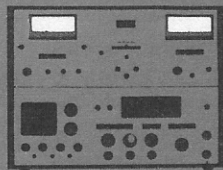
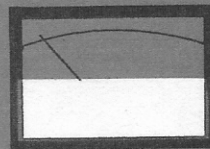
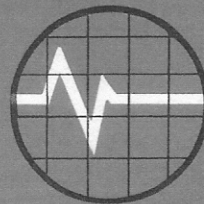



# **PAGING PRODUCTS - CODE PLAN GUIDE**

**PREPARED BY  
NATIONAL SERVICE TRAINING DEPARTMENT  
PLANTATION, FLORIDA  
JUNE, 1979**

## Table of Contents

	Page Number
I. Motorola Paging Systems and Applications	
1. Introduction .....	1
2. Paging Formats .....	1
3. Applications .....	4
II. Two-Tone Tone Coding	
1. Introduction .....	5
2. General Encoding .....	7
3. Code Type Encoding .....	8
4. "METRO-PAGE" System Encoding .....	8
5. Subaudible .....	8
III. Group Call	
1. Introduction .....	9
2. Code Type (Group Call) .....	9
3. "METRO-PAGE" (Group Call) .....	9
IV. Alternate Receiver Selection	
1. Introduction .....	10
2. General Encoding .....	10
3. Code Type Encoding .....	10
V. "Modax" 100, "Modem" 100, 36, and Alert Central	
1. Introduction .....	10
2. Paging Code Plans .....	11
3. Tone Groups .....	11
VI. N1016, 17, 18, and 19 Tone Coding .....	11
VII. Metro-Page 1, 2, & S Paging Terminal Tone Coding	
1. Introduction .....	12
2. Code Plans .....	12
3. Two-Tone Codes .....	12
4. 5-Tone Codes .....	12
VIII. Tone Coding Tables .....	13
IX. Appendix Groups 10 and 11 .....	17



# I. MOTOROLA PAGING SYSTEMS AND APPLICATIONS



## 1. Introduction

This publication describes the various tone signalling techniques employed by Motorola to selectively transmit a coded signal to an individual receiver or to a small group of selected receivers. Tone coded techniques and Decimal Digital coded techniques are explained. However, this publication does not cover Binary Decimal Coding, nor does it describe the encoding equipment (at the transmitter end) or the decoding equipment (at the receiving end) used in the various systems.

Coding techniques are required for radio paging systems and for selective call "Handie-Talkie" two-way radios. The need for special coded transmissions grew over the years as more and more people began using the available radio channels. The luxury of having a transmitting frequency (or channel) for your exclusive use could not be permitted in many areas. Therefore, some techniques were required to permit calling only the desired party, while not calling everyone else sharing the same frequency or channel.

To selectively signal one receiver in a system it must respond to only one coded transmission. Each pager or receiver will have a unique code as determined by plug-in filters or a code plug. Simple code plans were developed for the first paging systems to provide an orderly method of keeping track of these pagers, prevent duplicating of codes and minimize falsing problems. As the RF channels became more crowded, new code plans and signaling formats were added. This publication will cover the various formats and code plans. It will also identify which code plans are used with the old and new manual encoders and dial interconnect paging terminals.

## 2. Paging Formats

Motorola has developed an extensive line of pagers and signalling systems specifically tailored for each application. Several signalling formats were developed to meet these various requirements. Figure 1 explains the different formats and their relative comparisons in systems operation.

CODE FORM	PAGING TIME	MAX. PAGERS/ RF CHANNEL
<b>TWO-TONE SEQUENTIAL</b>		
TONE & VOICE (T & V)	4 SEC. & VOICE MESSAGE	APPROX. 500
TONE ALERT (TA)	2.5 SEC.	3540
TONE ALERT W/BATTERY SAVER	4.8 SEC.	3540
GROUP CALL (T & V and TA)	9.3 SEC. & VOICE (IF USED)	SEE TEXT
SUB-AUDIBLE (TA)	7 SEC.	870
DECIMAL DIGITAL	.2 SEC.	APPROX. 100,000

FIGURE 1

Two-tone sequential paging, as the name implies, consists of two tones transmitted in sequence. These tones are in the audible frequency range between 288 Hz and 1433 Hz. The 60 available tones allow for 3540 unique codes to be used. These 60 tones are divided into 6 groups, designated tone groups 1 through 6. Figure 2 shows the various two-tone code formats used

in Motorola systems.

Sub-audible paging is a variation of the standard two-tone. The 30 paging tones, however, are all in the sub-audible range between 67 Hz and 202 Hz. These 30 tones are divided into 3 groups labeled group 17, 18 & 19. The 30 sub-audible tones allow for 870 codes.

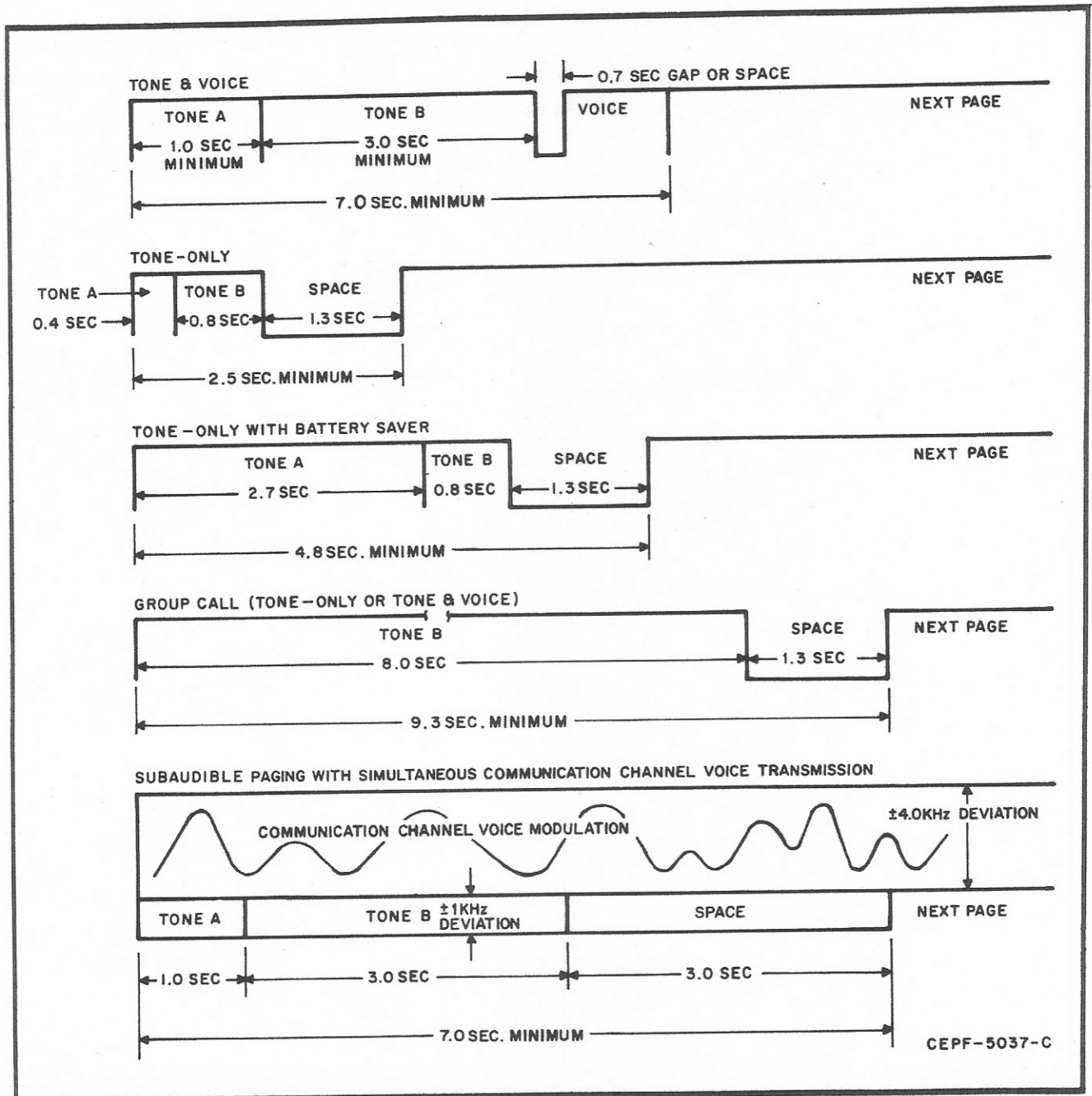

FIGURE 2

Decimal digital paging is initiated by transmitting a carrier that is normally frequency modulated by a preamble tone and five or six sequential pager address code tones. Figure 3 shows the decimal digital format. The basic signaling pattern consists of an optional 690-millisecond preamble tone, a 45-millisecond gap of unmodulated carrier, five sequential tones, each 33 milliseconds long, and either a 52-millisecond gap (5-tone page) or 52 milliseconds of special tone X (6-tone page). Tone X is used only to implement call "two" of the dual-alert pager and is not used in the

five-tone sequence (call "one").

The pager address code that each pager responds to is determined by the code programmed into its code plug. Twelve frequencies are used to represent digits 0 through 9, repeat tone R, and special tone X; refer to the digit coding table on figure 3. The repeat tone is substituted automatically for the second of two identical successive digits whenever they appear in the address code. For example, an address code of 13387 is converted to 13R87.

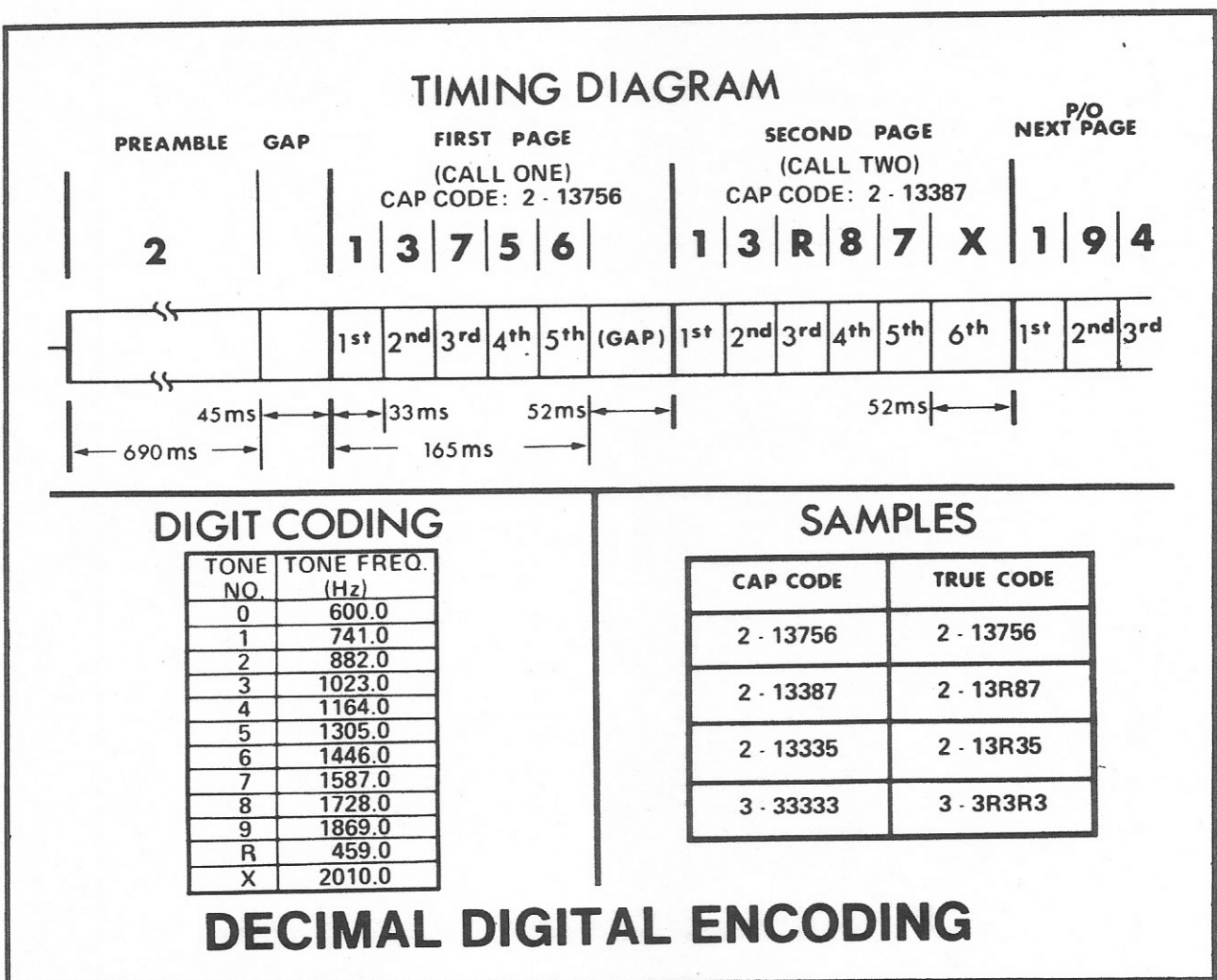

FIGURE 3

### 3. Applications

Tone and Voice paging is the most flexible of all paging formats. It allows the subscriber to be alerted and then be given a voice message. This allows the subscriber to receive the greatest variety of messages, but it restricts service to only about 500 subscribers per RF channel as tone and voice paging uses the greatest amount of air time. In addition to being subscriber restricted, the tone and voice coding format must rely on single transmitter coverage. Simultaneous transmissions can be difficult because of possible voice distortion in areas of over-lapping coverage from two or more transmitters. There are no effective voice storage terminals available to allow the message to be repeated several times over different transmitters to provide sequential transmissions.

Group call is a variation of tone and voice paging which allows a group consisting of several people to be paged simultaneously. The following voice message then directs the subscriber to the group activity. Tone and voice group call takes about 30% longer in time to transmit and the number of groups are limited by the number of tones generated by the encoder. Group call is an option which can be added to most pagers.

A specialized form of group call signalling was designed for use in competitive systems. Dual call three-tone group call was initially designed to interface with Plectron paging systems and is currently used with only a few Tone & Voice model pagers. However, it can be used in Motorola systems. A pager using this system is capable of responding to two separate two-tone sequential signals, one being a group call. The three-tone group call format is completely different and incompatible with the standard single tone version (long tone B type). The three tone system does allow more pagers per group, but less groups. For further details on dual call three-tone group call signalling, refer to System Planner R4-1-62A.

Tone Alert Paging two-tone sequential is the most reliable scheme in terms of system coverage and in operating in areas of fades and nulls. While tone alert paging lacks the message flexibility of tone and voice paging it can provide service to a larger number of subscribers, 3540 per channel. Group call paging is also optional.

Tone alert paging provides better coverage than tone and voice paging using single transmitter operation. This is because the decoder sensitivity is better than the squelch sensitivity in a voice pager, i.e. the decoder can "hear" its message even when the subscriber's ear cannot clearly distinguish a comparable voice message.

Sub-audible Tone Alert (two-tone sequential) paging was designed for customers who do not have a paging only channel. This coding system is used to superimpose radio paging on an RF channel which is simultaneously serving other communications, such as, mobile two-way radio. With sub-audible paging, 870 tone-only subscribers can be added to a channel. Sub-audible is also an ideal method to combine tone-alert paging on an existing tone and voice system. This would allow the carriers to readily expand into tone-alert without compromising his tone and voice capacity.

Sub-audible should be used only if a paging only channel is not available. There are several cautions when using sub-audible:

1. Sub-audible cannot be used in any system that uses PL.
2. Simultaneous transmitters cannot be used with sub-audible tones.
3. Local control base station operation is required because of the low tone frequencies 67 to 202 Hz used for subaudible paging. Remote operation requires special high cost telephone lines between the encoder and the base station or having the encoder generate eight (times) subaudible tones and a divide by an eight kit at the base station.

Sub-audible is an excellent way to provide paging along with radiotelephone service in small cities where the carrier has only one station as it minimizes the fixed equipment investment.

Tone-Alert Decimal Digital (Five-Tone Format) provides for the greatest density of subscribers per RF channel. Up to 100,000 subscribers can be served on a single channel. Decimal Digital systems can operate with simultaneous or sequential transmitters. The Decimal Digital format is twelve and one-half times faster than the two-tone (.2 sec. vs 2.5 sec.).

## II. TONE CODING

### 1. Introduction

Motorola tone coded pagers use several code plans which have evolved over a period of time as the number of pagers in operation increased. A cap code system was devised to identify the filters used in the pagers. Originally, each code plan used a different cap code plan so the code plan being used could be identified by the pager's cap code numbers or letter prefix. However, the new dial interconnect paging terminals can use all the various code plans and sometimes the user will place the telephone number on the pager in place of the cap code. Another exception is the plans used with the "Modem" 36 and Alert Central encoders.

This section will cover the three basic code plans and cap codes. The cap code scheme used in the Metro 1, 2, & S paging terminal and the "Modem" 36 and the

Alert Central encoders will be covered separately to explain the minor variations.

The relationship between the pager code number and the filters selected for the pager is established by the encoding system used. The encoding system used is a function of the paging terminal and is normally dictated by the number of pagers in the system. The relationship between the cap code and the encoding scheme being used is shown in table 1. The relationship between the paging terminal, the encoding system, and various tone groups is shown in table 1A. Table 1A indicates that MOTOROLA dial interconnect terminals and encoders use three basic code plans; General, Code Type, and "Metro-Page", with minor variations. In addition, the newer encoders and terminals can be set up to handle 5-tone, Quick-Call, G.E., and Bell & Howell code plans. The following tables will list the various code plans and indicate which terminals and encoders are applicable.

PAGER CODE TYPE	ENCODING METHOD USED
THREE-DIGIT CODE (625)	GENERAL, MODIFIED GENERAL ENCODING.
THREE-DIGIT CODE WITH A LETTER PREFIX (D476)	HIGH CAPACITY ENCODING METHOD (CODE TYPE)
THREE-DIGIT CODE WHERE THE SECOND AND THIRD DIGITS ARE THE SAME (366)	ALTERNATE PAGER ENCODING METHOD (GENERAL)
THREE-DIGIT CODE WHERE THE SECOND AND THIRD DIGITS ARE THE SAME AND INCLUDES A LETTER PREFIX (B455)	HIGH CAPACITY ALTERNATE PAGER ENCODING METHOD (CODE TYPE)
THREE-DIGIT CODE WITH OR WITHOUT A LETTER PREFIX AND ANOTHER THREE DIGIT CODE WHERE THE SECOND AND THIRD DIGITS ARE THE SAME (B465/255)	GROUP CALL ENCODING METHOD (CODE TYPE)
FOUR-DIGIT CODE (1725)	HIGH CAPACITY ENCODING METHOD (METRO-PAGE OR CODE TYPE)
FOUR-DIGIT CODE AND ANOTHER FOUR DIGIT CODE WHERE THE THIRD AND THE FOURTH DIGITS ARE THE SAME 1523/1533	GROUP CALL HIGH CAPACITY ENCODING METHOD (METRO-PAGE OR CODE TYPE)
FIVE-DIGIT CODE 53416	DECIMAL DIGITAL ENCODING SINGLE FUNCTION
FIVE-DIGIT CODE FOLLOWED BY A SLASH MARK AND A SIXTH DIGIT 52786/7	DECIMAL DIGITAL ENCODING DUAL FUNCTION

TABLE 1



TABLE 1A

NO. OF PAGERS IN SYSTEM	TERMINAL TYPE AND MODELS	CODING SYSTEM	*TONE GROUPS
2 6 12 20	N1016 N1017 N1018 N1019	MODIFIED GENERAL	1 THROUGH 5 7, 8, 9  QUICK CALL
870	N1055 SERIES	GENERAL	1,2,4,5
870	L08 SERIES	CODE TYPE (STANDARD) (SUBAUDIBLE)	1 THROUGH 6 17, 18, 19 (or 7,8,9)
870	L09 SERIES	CODE TYPE (STANDARD) (SUBAUDIBLE)	1 THROUGH 6 17, 18, 19 (or 7,8,9)
2450	N1002 SERIES	CODE TYPE (STANDARD) METRO-PAGE (SUBAUDIBLE)	1 THROUGH 5 1 THROUGH 5 17, 18, 19 (or 7,8,9)
100,000	"METRO- PAGE" 10 & 100	METRO-PAGE (STANDARD) (SUBAUDIBLE) DECIMAL DIGITAL	1 THROUGH 6 *** 17, 18, 19 (or 7,8,9) DECIMAL DIGITAL
870 **870/970/1000 10,000	METRO-PAGE S METRO-PAGE 1 METRO-PAGE 2	METRO-PAGE CODE TYPE (STANDARD) (SUBAUDIBLE) DECIMAL DIGITAL	1 THROUGH 6 ***  1 THROUGH 6 17, 18, 19 DECIMAL DIGITAL G.E. A, B, C BELL & HOWELL
**870/970	MODAX 500	CODE TYPE (STANDARD) (SUBAUDIBLE)	1 THROUGH 6 *** 17, 18, 19
870	MODEN 900	CODE TYPE (STANDARD) (SUBAUDIBLE)	1 THROUGH 6 *** 17, 18, 19 QUICK CALL G.E., A, B, & C
5 30 90	ALERT CENTRAL MODEN 36 MODEN 100	MODIFIED GENERAL (STANDARD) (SUBAUDIBLE)	1 THROUGH 6 *** 17, 18, 19 G.E. A, B, C QUICK CALL
90	MODAX 100	MODIFIED GENERAL (STANDARD) (SUBAUDIBLE)	1 THROUGH 6 *** 17, 18, 19 G.E. A, B, C, QUICK CALL

\*TONE GROUP TABLES ARE LOCATED IN THE BACK OF THIS PUBLICATION SECTION VII

\*\*CODE PLAN DEPENDENT

\*\*\*GROUPS 10 & 11 ARE AVAILABLE FOR CERTAIN PAGING TERMINALS. (SEE APPENDIX "A")

## TONE ALERT PAGING

MOTOROLA Tone-Alert radio pagers used in low capacity systems employ two-tone sequential signaling. Two discrete audio tones modulate a carrier and are transmitted for a specific period of time. The duration of these tones is dictated by the pager used in the system. Battery saver, group call, or subaudible model pagers tone timing is shown on the following chart.

MODEL OPTIONS	TRANSMISSION TIME		
	1ST TONE (A)	2ND TONE (B)	INTERPAGE GAP (MIN)
BASIC (WITHOUT BATTERY SAVER OR SUBAUDIBLE)	0.4 SEC.	0.8 SEC.	1.3 SEC.
GROUP CALL	0 SEC.	8 SEC.	3.0 SEC.
BATTERY SAVER	2.7 SEC.	0.8 SEC.	1.3 SEC.
SUBAUDIBLE	1.0 SEC.	3.0 SEC.	3.0 SEC.
GROUP CALL	0 SEC.	8 SEC.	3.0 SEC.

There are 90 standard discrete tone frequencies from which Tone A (1st tone) and Tone B (2nd Tone) may be selected. Each of these individual frequencies is assigned a code number. The code number is referred to as the "filter code" or "reed code" and is stamped on the body of the active filter or reed (which will be referred to as filter for this discussion) passes that tone frequency. To facilitate the coding procedure, the 90 separate tone frequencies and filter codes are divided into nine groups numbered Tone Group 1, through Tone Group 6 and Tone Group 17 through Group 19. The filters selected for Tones A and B plug into the radio pager printed circuit board. When a signal containing the proper tone frequencies in the proper sequence is received by the radio pager, the filters pass the frequencies and the pager emits an alert tone.

## TONE & VOICE PAGING

MOTOROLA Tone and Voice radio pagers also use two-tone sequential signaling. Two discrete audio tones are transmitted for a specific period of time. The tones are transmitted as follows:

	TRANSMISSION TIME		
	1ST TONE (A)	2ND TONE (B)	INTERPAGE GAP (MIN)
TONE AND VOICE MODELS	1 SEC.	3 SEC.	1.3 SEC.
GROUP MODELS	0 SEC.	8 SEC.	3 SEC.

Each pager in the system responds to a unique combination of tones. This combination is determined by the filters installed in the pager. There are 60 unique tone frequencies from which Tones A and B may be selected. These are the same tones used for Tone-Alert pagers, Tone Groups 1 through 6. Every pager has a cap code that appears in a small window on the clip or the reset bar of the pager. Tables 1 & 1A explained the various cap codes and codes used with different paging terminals and encoders. The next few pages will explain the code plans and encoding methods in more detail.

## 2. General and Modified General Encoding

The 1055 series dial interconnect terminal is the only encoder that uses the General Encoding plan. All manual encoders under 100 call capability use the Modified General Encoding plan. These small manual encoders are capable of generating both Tone A and B frequencies from only one of the 6 tone groups at a time. Therefore, the Modified General Encoding plan is used (refer to Table 2A). Note: small encoder manuals referring to the General Encoding plan are in error.

### (A) GENERAL ENCODING

Each pager using the general encoding system is assigned a three-digit "pager code." The relationship between the "pager code" and the filters installed in the pager is established by this encoding method.

The first digit of the three-digit pager code determines the groups from which Tone A and Tone B will be selected, as indicated in Table 2. The next two digits of the pager code further identify Tones A and B respectively, within the two tone groups selected in Table 3. Tables 2 through 14 are located in Section VIII at the back of this publication.

To determine the tone frequencies or filter codes associated with a given pager, proceed as follows:

- (1) Locate the first digit of the pager code in the first column of Table 2.
- (2) In columns 2 and 3 of Table 2, find the tone group numbers for Tone A and Tone B that correspond to the first digit of the pager code.
- (3) Locate the second digit of the pager code in the first column of Table 3, this is the tone number for Tone A. Locate the tone group number for Tone A in Table 3 (determined in Step 2). The filter number and frequency are indicated for Tone A under the tone group.
- (4) Locate the third digit of the pager code in the first column of Table 3. This is the tone number for Tone B. Locate the tone group number for Tone B in Table 3 (determined in Step 2). The filter number and frequency are indicated for Tone B under the reed group.

**EXAMPLE:**

Pager Code 635 -

Tone A = Filter Code 123, Frequency 669.9 Hz  
 Tone B = Filter Code 115, Frequency 433.7 Hz

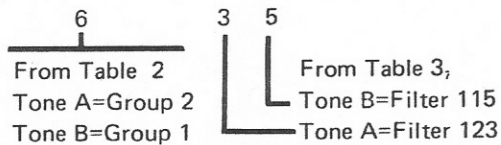

**(B) MODIFIED GENERAL ENCODING**

Pager codes using Modified General Encoding plan can be broken down into Tone A and Tone B frequencies using the same method as the General Encoding just described by substituting reference to Table 2 with Table 2A.

**3. Code Type Assignment Method**

Each radio pager in a code type system is assigned a three-digit code number with a letter prefix. The letter prefix is the "code type" designation. The code type letter and the first digit of the pager code number determine the tone groups for Tones A and B. The second digit determines the Tone A code number and frequency. The third digit determines the Tone B code number and frequency. The particular Tone A and Tone B filter code numbers and frequencies are identified by reference to tables. For example, assume a pager code of D476. Tones A and B are identified as follows:

- (1) Find the first digit of the pager code (4) in the first column of Table 4; the tone groups (1 and 5) are found across from 4, in the A and B columns under D.

- (2) Refer to Table 3 and locate the second digit of the pager code (7) in column 1; the code and frequency of Tone A (CODE 117, FREQ 483.5 Hz) are found directly to the right of 7 and under GROUP 1.
- (3) Refer to Table 3 again and locate the third digit of the pager code (6) in column 1; the code and frequency of Tone B (CODE 156, FREQ 767.4 Hz) is found directly to the right of 6 and under GROUP 5.

**4. "Metro-Page" System Encoding**

When a pager is used with a "Metro-Page" Encoding System, the pager code is a four digit number. The groups for Tones A and B are determined by the first two digits of the pager code as indicated in Table 5. The filter for Tones A and B are then selected from Table 3 in accordance with the third and fourth digits of the pager code. For Example: to determine the filter assignments for pager 1645, proceed as follows: Look up the first two digits of the pager code (16) in Table 5. Groups 2 and 1 are shown for Tone A and Tone B respectively. Now refer to Table 3 in the tone group two column on the line corresponding to the third digit of the pager code (4). Filter code 124, frequency 707.3 Hz is shown as the Tone A filter. For the Tone B filter refer to the line corresponding to the fourth digit of the pager code (5) in the tone group 1 column. Filter code 115, frequency 433.7 Hz is shown as the Tone B filter for this pager.

Summary: Pager 1645 will have the following filters installed:

Tone A = Filter Code 124, Frequency 707.3 Hz  
 Tone B = Filter Code 115, Frequency 433.7 Hz

**5. Subaudible Coding**

The subaudible coding method is the same as the "Code Type Assignment" method except that special low-frequency filters are used. The subaudible frequencies must be used when paging is used in a common carrier radio communication system. They may also be used to increase the pager capacity on a single frequency.

Thirty subaudible frequencies are available. These are designated code type Z with tone groups 7, 8, and 9 or code type AZ with tone groups 17, 18, and 9. The Tone A and Tone B codes and frequencies may be identified by reference to Tables 6 and 7.

# III. GROUP CALL CODING

## 1. Introduction

Pagers with the group call option are assigned two code numbers, one for individual call and one for group call. If the individual code number is used, it alone will be alerted as a standard pager. If the group call number is used, all of the other pagers in the same group will be alerted along with this pager. A pager with the group call option is assigned filters in the same way as the standard pager. However, only pagers with the same Tone B filter are grouped for simultaneous call.

## 2. Group Call (Code Type)

Group call codes consist of three digits and a letter prefix with repeated second and third digits. The first digit and letter prefix indicates the tone group from which the Tone B filter is selected. The second and third digits show the specific filter selected from that group. A typical group call pager might be coded B465/255. The first number is the individual call code and the next number is the group call code. According to the code assignment table and the filter code table, the following filters are installed in this pager.

Tone A = Filter Code 116, Frequency 457.9 Hz (Filter 6 of Group 1)

Tone B = Filter Code 125, Frequency 746.8 Hz (Filter 5 of Group 2)

The group call number of this pager (255) verifies that filter 5 of group 2 is used in the Tone B position. The last digit of the individual call code will always be the same as the second and third digits of the group call number because of the Tone B interrelationship noted above. Also, because of the group requirement for a common Tone B, an additional restriction is applied to individual codes to be grouped. The first digit and letter prefix of the individual number must indicate a Tone B filter selection from the same group shown by the first digit of the group call code. For instance, pager (B465/255) cannot be grouped with pager B565 even though the last digits are the same. First digit 5, code type B, indicates a Tone B selection from filter group 3 according to the Code Assignment table. This pager cannot use group call code 255.

Refer to Table 4, the code plan table. Note that for a high capacity system with three tone groups in use, three different first digits will select the same tone group for Tone B for each code plan. For example, in the code type C column, the first digits 1, 6, and 7 all specify tone group 1 for the Tone B selection. Therefore, the following pagers in this system will have the same Tone B filter installed and may be grouped for simultaneous call:

C101, C121, C131, C141, C151, C161, C171, C181, C191  
Total 9 pagers

C601, C611, C621, C631, C641, C651, C661, C671, C681, C691 Total 10 pagers  
C701, C711, C721, C731, C741, C751, C761, C771, C781, C791, Total 10 pagers  
Group - total 29 pagers

The group call number for all of these pagers would be C111. Note that individual pager code C111 has been excluded. Since first digit 1 selects the same group for Tones A and B, a pager with this first digit and repeating second and third digits would never be assigned in a system with this code type, because it would have the same Tone A and Tone B filters installed. For each code type there are three first digits that will specify the same groups for Tones A and B. In code plan C these digits are 1, 2, and 4. no pagers will be assigned in code type C with these first digits and repeating second and third digits.

The maximum number of pagers that may be included in a group is equal to the total number of paging tones available in the encoder, minus one. The maximum number of groups in a system is equal to the number of paging tones available.

For example: A 90-call encoder has 10 tones and will accommodate up to 10 groups of 9 pagers each. An 870-call encoder has 30 tones and a maximum group call capacity of 30 groups with 29 pagers in each group.

## 3. Group Call ("Metro-Page" Coding)

Group call for pagers using the "Metro-Page" coding scheme is very similar to pagers using the code type plan. A pager using the "Metro-Page" code plan would be assigned two code numbers; i.e., 1234/1244. Using Table 5 indicates that both Tone A and Tone B are from the same group; that is, tone group 2. The terminal recognizes that both Tone A and Tone B are from the same group and that the same tone is to be generated for Tone A and Tone B making it a group call and extended the duration of this tone to 8 seconds for pager code 1244. Tone 4 from group 2 will alert all pagers in the system with the group call option installed and a Tone B filter code 124, frequency 707.3 Hz. Therefore, the following pagers may be grouped for simultaneous call:

1004, 1014, 1024, 1034, 1044, 1054, 1064, 1074, 1084, 1094, 1204, 1214, 1224, 1234, 1254, 1264, 1274, 1284, 1294, 1304, 1314, 1324, 1334, 1344, 1354, 1364, 1374, 1384, 1394, 2604, 2614, 2624, 2634, 2644, 2654, 2664, 2674, 2684, 2694, 3404, 3414, 3424, 3434, 3444, 3454, 3464, 3474, 3484, 3494, 4104, 4114, 4124, 4134, 4144, 4154, 4164, 4174, 4184, 4194

The "Metro-Page" terminal using the "Metro-Page" code plan could have a maximum of 60 group calls with 59 pagers per group.

## IV. ALTERNATE RECEIVER SELECTION

### 1. Introduction

Two methods are used for alternate receiver selection, the first systems used on earlier dial interconnect paging terminals used non-standard tones. An alternate receiver selection plan was used for both the General Encoding and the Code Type Plan. Current dial interconnect paging terminals use a memory or a diode matrix for alternate receiver selection and the standard tones and coding schemes are used.

In the earlier dial interconnect terminals there was a provision for substituting spare receivers into the system should any of the "on-line" paging receivers be out of service. The pager substituted into the system uses a coding method different than the general encoding method described earlier.

Alternate receivers may be substituted for group call pagers if the alternate unit has the group call option installed and the same group call number assigned. If an alternate receiver without the group call option is used in the place of a group call pager, the alternate receiver will respond to the individual pager code but not to a group call. When several groups are in use, alternate receivers with the group call option should not be substituted for pagers with different group call numbers, or pagers without the group call option. This type of substitution will result in a false alert when the alternate receiver group is paged.

### 2. General Encoding Assignments (Alternate Receiver Encoding Method)

The spare receivers are identified by an alternate pager code which has the same second and third digits, i.e., 122. The alternate pager decoding method uses the first digit to select Tone A directly and the tone group from which Tone B is selected. The third digit of the alternate pager code is

the tone number of Tone B selected from the tone group associated with the first digit in Table 8. Table 8 illustrates the alternate pager encoding method. The tone groups referenced for Tone B are the same as in Table 3.

To find the tone frequencies or filter codes corresponding to an alternate pager code, use Table 8 and the alternate pager code's first digit to determine Tone A and the group from which Tone B is selected. Then use Table 3 and the alternate pager code's third digit to determine Tone B.

Example:

Given alternate pager code 355  
Tone A: Filter Code 130 (979.9 Hz)  
Tone B: Filter Code 125 (746.8 Hz)

### 3. Code Type Assignments (Alternate Receiver Encoding Method)

Alternate receivers in systems using this type of encoding have pager codes prefixed with the system code type letter. The Tone A filter and group specified by the first digit of this pager code vary with the code type letter. To obtain this information, refer to Table 9. To determine Tone B, the normal procedure is used.

Example: Alternate pager B355; Refer to Table 9 in the code type B column. On line 3, Tone A filter code S20, frequency 1500 Hz and Tone B selection from group 3 is indicated. In Table 3, on line 5, column 3, filter code 160, frequency 953.7 Hz, is indicated for Tone B.

Summary: Alternate pager B355 has the following filters installed. See Table 9 and Table 3.

Tone A = Filter Code S20, Frequency 1500 Hz  
Tone B = Filter Code 160, Frequency 953.7 Hz

## V. "MODAX" 100, "MODEN" 100, 36, AND ALERT CENTRAL

### 1. Introduction

Motorola radio paging systems employing the "Modax" 100, "Moden" 100, "Moden" 36, and Alert Central Paging Encoders use two-tone sequential signaling with the Modified General Encoding Plan.

The tone frequencies used with these encoders are

selected from any one of six tone groups. Each of these tone groups contain ten frequencies. (Refer to Tables 2A, 3, 7, 12, & 13). Through the use of the tables and the pager code (cap code) the frequencies of the two audio selective elements used in the pager decoding circuit can be determined.

## 2. Paging Code Plan

These paging encoders can be programmed for any one of six tone groups from Table 3. They can also be programmed for subaudible, "Quick-Call" and General Electric plans. (Refer to Tables 7, 12, & 13).

In paging systems using a "Modem" 100/36, "Modax" 100 or Alert Central, the cap code consists of three digits (modified general encoding plan). The first digit is used to determine from which tone group the first and second tones are selected. For example, assume that the pager to be paged has a cap code of 635. The most significant digit is (6) which means that the first tone and the second tone will be from Group 6. (Refer to Table 2A.) The second and third digits of the call code determine the tone number selected from the tone group. The second digit, number (3) indicates the first tone to be tone number 3 of tone group 6 (1217.8 Hz). The third digit, number (5) indicates the second tone to be tone number 5 (1285.8 Hz).

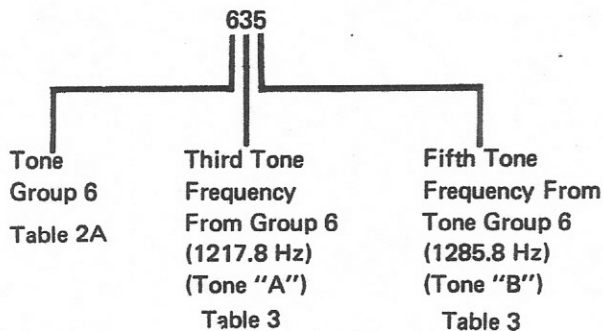

## 3. Tone Groups

For the "Modem" 36 and Alert Central Paging Encoders, the tone groups are broken into upper and lower tone groups. The upper tone group consists of tone numbers zero through five (0, 1, 2, 3, 4, 5), and the lower tone group consists of tone numbers five through nine and zero (5, 6, 7, 8, 9, 0). Refer to Table 11 for an example of Group 1. All tone groups used with "Modem" 36 and Alert Central Encoders are divided into upper and lower groups in a similar manner.

The "Modem" 36 and the Alert Central keyboard uses only the numbers 0 through 5. To correlate the pager cap code and the encoder keyboard, use the following information. For pager cap codes 1XY where digits represented by X and Y are less than or equal to 5, the upper tone group is used and the digits are entered directly.

Example:

Cap Code 143 Keyboard Entry 43

Tone A = 410.8 Hz

Tone B = 389.0 Hz

When X or Y is greater than 5 or 0, the lower tone group is used. Table 11 is used to determine the keyboard entry.

Example:

Cap Code 168 Keyboard Entry 13

Tone A = 457.9 Hz

Tone B = 510.5 Hz

## VI. N1016, 17, 18, AND 19 TONE CODING

The tone groups for the N1016 - N1019 series encoders (Refer to Tables 3, 7, 12, 13) are broken into upper and lower portions. Unlike the tone coding for "Modem" 36 and Alert Central Paging Encoders, the tone groups are divided in half. The first five tones (1, 2, 3, 4, 5) are the upper half labeled Tone Number 1 through Tone Number 5, the last five tones (6, 7, 8, 9, 0) are considered the lower half and are also labeled Tone Number 1 through Tone Number 5. Therefore, in order to determine the frequencies of the two audio selective elements from the pager's cap code, it must first be determined if the encoder is programmed for the upper or lower portion of the tone groups. Refer to Table 11A

for an example of Group 1. All tone groups used with N1016, 17, 18, 19 are divided into upper and lower groups in a similar manner.

Example: Encoder programmed for upper Group 1

Cap Code 143 Keyboard Entry 43

Tone A = 410.8 Hz

Tone B = 389.0 Hz

Example: Encoder programmed for lower Group 1

Cap Code 143 Keyboard Entry 43

Tone A = 539.0 Hz

Tone B = 510.5 Hz

# VII. METRO 1, 2, & S TONE CODING

## 1. Introduction

Depending on the model and options ordered, "Metro-Page" terminals are capable of encoding the following types of pages:

- Two-tone, tone-only (2.5 or 5-second call rate)
- Two-tone, tone-and-voice (5-second call rate)
- Sub-audible, two-tone, tone-only (7-second call rate)
- Two-tone, pager group call (8-second call rate)
- Five-tone, decimal digital, tone-only (0.2-second call rate) dual function
- GE two-tone (except codes containing the "diagonal" tone)

## 2. Code Plans

The code plan sets the general correspondence of dialed-in numbers and receiver codes.

Motorola two-tone code plans B through W and Z, the Metro-Page paging two-tone code plan and the five-tone decimal digital code plan are available in the Metro-Page 1 and 2 terminals. The Metro-Page S terminal is normally only used with code plan Z (sub-audible).

## 3. Two-Tone Codes

Refer to Table 14 for a listing of these code plans and how they are accessed. You will note that the lettered code plans are all paired; i.e., plan B and W, plan E and T, etc. This means that a terminal equipped for code plan B is also capable of encoding code plan W. You will also note that this same coding scheme can encode sub-audible (prefix 71-79) and GE (prefix 60-68) codes. Only one paired code plan can be furnished in any one terminal. Paired combinations other than those included in the table are a special order. Their use will result in some code duplications; i.e., pairing B and C would result in duplication of tone group pairs 1,1 and 2,2. The code plan pairs as shown provide the optimum pairing, in that all tone groups are available in all code plans. Optionally, the terminal may be equipped with the "Metro-Page" paging two-tone code plan *in place of* a letter-coded, paired two-tone code plan. As with the letter-paired plans, the "Metro-Page" paging two-tone plan is also capable of encoding sub-audible and GE codes.

For any plan, call tones are determined by a four-digit number. The first two digits correspond to the "prefix" digits shown in Table 14. They determine which code group(s) the two tones will come from. The last two digits designate the tones within those groups. For example, in a terminal equipped with code plans D/U, the codes on Figure 4 would be generated for the given input numbers.

### NOTE

Tables 3, 7, 12 and 13 lists the frequency of the individual tones within a group.

Input #	1st Tone		2nd Tone	
	Group	Tone #	Group	Tone #
0579	5	7	5	9
0632	2	3	1	2
1528	3	2	6	8
1957	6	5	4	7
6425	G3	2	G3	5
7613	19	1	18	3
			(GE Codes)	(Sub-audible)

Figure 4

Paging group call is generated whenever the last two digits of a pure tone group (1st and 2nd tone from the same group) are the same. In the example above, if the first input number were 0533 instead of 0579, a group call would be sent. It would consist of 8 seconds of tone 3 from tone group 5.

## 4. Five-Tone Codes

The first tone of the five-tone sequential code is hard-wire programmed into the terminal. It will be the same for all five-tone codes on a given terminal. The next four tones are determined by the four input digits and are directly related to those input digits. For example, in a terminal where the first tone is programmed to be tone 1, the following inputs will cause the tones indicated to be transmitted:

Input #	Tones				
0357	1	0	3	5	7
2691	1	2	6	9	1
5332	1	5	3	R	2
1122	1	R	1	2	R

Note repeat tone

Table 2 General Encoding Plan

FIRST DIGIT OF PAGER CODE	GROUP FROM WHICH TONE A IS SELECTED	GROUP FROM WHICH TONE B IS SELECTED
1	1	1
2	2	2
3	1	2
4	4	4
5	5	5
6	2	1
7	4	5
8	5	4
9	2	4
0	4	2
A	3	3

VIII. TONE CODING TABLES

Table 2A Modified General Encoding Plan

1st Digit of Cap Code	Tone A (Grp)	Tone B (Grp)
1	1	1
2	2	2
3	3	3
4	4	4
5	5	5
6	6	6

Table 3 Tone Groups (Filter Codes & Tone Frequencies)

		TONE GROUP 1		TONE GROUP 2		TONE GROUP 3		TONE GROUP 4		TONE GROUP 5		TONE GROUP 6	
		CODE	FREQ. (HZ)	CODE	FREQ. (HZ)	CODE	FREQ. (HZ)	CODE	FREQ. (HZ)	CODE	FREQ. (HZ)	CODE	FREQ. (HZ)
PAGER CODE DIGIT	1	111	3490	121	600.9	138	288.5	141	339.6	151	584.8	191	1153.4
	2	112	368.5	122	634.5	108	296.5	142	358.6	152	617.4	192	1185.2
	3	113	389.0	123	669.9	139	304.7	143	378.6	153	651.9	193	1217.8
	4	114	410.8	124	707.3	109	313.0	144	399.8	154	688.3	194	1251.4
	5	115	433.7	125	746.8	160	953.7	145	422.1	155	726.8	195	1285.8
	6	116	457.9	126	788.5	130	979.9	146	445.7	156	767.4	196	1321.2
	7	117	483.5	127	832.5	161	1006.9	147	470.5	157	810.2	197	1357.6
	8	118	510.5	128	879.0	131	1034.7	148	496.8	158	855.5	198	1395.0
	9	119	539.0	129	928.1	162	1063.2	149	524.6	159	903.2	199	1433.4
	0	110	330.5	120	569.1	189	1092.4	140	321.7	150	553.9	190	1122.5

Table 4 Code Type Assignment Coding Plan

CODE TYPE	B	C	D	E	F	G	H	J	K	L	M	N	P	Q	R	S	T	U	V	W	Y																						
SEQUENTIAL TONE	A	B	A	B	A	B	A	B	A	B	A	B	A	B	A	B	A	B	A	B	A	B																					
FIRST DIGIT OF PAGER CODE	1	1	1	1	1	1	1	1	1	1	1	1	1	1	2	3	2	3	2	3	2	4	2	4	2	5	3	4	3	4	3	5	4	6	A	A							
	2	2	2	2	2	2	2	2	1	3	1	3	1	3	1	4	1	4	1	5	2	2	2	2	2	2	2	2	2	4	3	4	3	5	3	6	4	B	B				
	3	3	3	1	2	1	2	1	2	3	3	3	3	3	3	3	4	2	4	2	5	2	3	3	3	3	3	3	3	3	3	5	6	Z	Z								
	4	1	2	4	4	1	5	2	1	4	4	3	1	3	1	4	4	4	4	1	6	4	4	3	2	3	2	4	4	4	2	6	4	4	4	3	6	4	A	B			
	5	1	3	1	4	5	5	1	6	3	1	5	5	1	6	5	5	1	6	5	5	3	2	5	5	2	6	5	5	2	6	5	5	5	3	6	5	5	A	Z			
	6	2	1	2	1	2	1	6	6	1	4	1	5	6	6	1	5	6	6	6	2	4	2	5	6	6	2	5	6	6	6	6	3	5	6	6	6	6	B	A			
	7	3	1	4	1	5	1	6	1	4	1	5	1	6	1	4	5	6	1	6	1	4	2	5	2	6	2	4	5	6	2	4	5	6	3	6	3	4	5	Z	A		
	8	2	3	2	4	2	5	2	6	3	4	3	5	3	6	5	4	4	6	5	6	3	4	3	5	3	6	5	4	4	6	5	6	5	4	4	6	5	6	5	4	B	Z
	9	3	2	4	2	5	2	6	2	4	3	5	3	6	3	5	1	6	4	6	5	4	3	5	3	6	3	5	2	6	4	6	5	5	3	6	4	6	5	6	5	Z	B
	*0	2	4	X	X	X	X	X	X	X	X	X	X	X	X	X	X	X	X	X	X	4	2	4	2	4	2	4	2	4	2	4	2	4	2	4	2	4	2	4	2	X	X

\* NOT AVAILABLE ON ALL PAGING TERMINALS OR ENCODERS.



**Table 5 "Metro-Page" Coding Plan**

FIRST TWO DIGITS	ZONE A GROUP	ZONE B GROUP
10	4	2
11	1	1
12	2	2
13	1	2
14	4	4
15	5	5
16	2	1
17	4	5
18	5	4
19	2	4
20	6	6
21	1	5
22	5	1
23	1	4
24	4	1
25	2	5
26	5	2
31	1	3
32	3	1
33	2	3
34	3	2
35	3	4
36	4	3
37	3	5
38	5	3
39	3	3
40	6	1
41	6	2
42	6	3
43	6	4
44	6	5
45	1	6
46	2	6
47	3	6
48	4	6
49	5	6

**Table 6 Subaudible Code Type Plan**

CODE TYPE	Z		AZ		
	A	B	A	B	
SEQUENTIAL TONE	1	7	8	17	18
	2	7	9	17	9
	3	8	7	18	17
	4	9	7	9	17
	5	8	9	18	9
	6	9	8	9	18
	7	7	7	17	17
	8	8	8	18	18
	9	9	9	9	9

**Table 8 General Alternate Pager Code Plan**

FIRST DIGIT OF ALTERNATE PAGING CODE	TONE A REED CODE FREQUENCY	REED GROUP FROM WHICH TONE B IS SELECTED
1	160 953.7	1
2	160 953.7	2
3	130 979.9	2
4	160 953.7	4
5	160 953.7	5
6	130 979.9	1
7	130 979.9	5
8	130 979.9	4

**Table 7 Subaudible Tone Groups**

	TONE GROUP 7		TONE GROUP 8		TONE GROUP 9		TONE GROUP 17		TONE GROUP 18		TONE GROUP 19		
	CODE	FREQ. (Hz)	CODE	FREQ. (Hz)	CODE	FREQ. (Hz)	CODE	FREQ. (Hz)	CODE	FREQ. (Hz)	CODE	FREQ. (Hz)	
TONE NUMBER	1	101	202.7	4A	141.3	1Z	100.0	101	202.7	4A	141.3	1Z	100.0
	2	7A	192.8	4Z	136.5	+WB	79.7	7A	192.8	4Z	136.5	WB	79.7
	3	7Z	186.2	3B	131.8	ZA	94.8	7Z	186.2	3B	131.8	ZA	94.8
	4	*6B	179.9	3A	127.3	ZZ	91.5	WZ	69.3	3A	127.3	ZZ	91.5
	5	6A	173.8	3Z	123.0	YB	88.5	6A	173.8	3Z	123.0	YB	88.5
	6	6Z	167.9	2B*	118.8	YA	85.4	6Z	167.9	WA	74.4	YA	85.4
	7	5B	162.2	2A	114.8	YZ	82.5	5B	162.2	2A	114.8	YZ	82.5
	8	5A	156.7	2Z	110.9	XB	77.0	5A	156.7	2Z	110.9	XB	77.0
	9	5Z	151.4	1B	107.2	XA	71.9	5Z	151.4	1B	107.2	XA	71.9
	0	4B	146.2	1A	103.5	XZ	67.0	4B	146.2	1A	103.3	XZ	67.0

\*TONE GROUPS 17,18,19 REPLACED TONE GROUPS 7,8,9. BECAUSE TONE 6B & 2B WERE TOO CLOSE TO HARMONICS OF 60Hz. SOME PAGING TERMINALS SHIPPED BEFORE 1972 WERE EQUIPPED

**Table 9 High Capacity Alternate Pager Code Type Plan**

CODE TYPE DESIGNATION	B	C	D	E	F	G	H	J	K	L	M	N	P	Q	R	S	T	U	V	W																					
SEQUENTIAL TONES FILTER CODE	A	B	A	B	A	B	A	B	A	B	A	B	A	B	A	B	A	B	A	B	A	B																			
FIRST DIGIT OF PAGER CODE	1	S20	1	S20	1	S20	1	S20	1	S20	1	S20	1	S20	1	S20	3	S20	3	S20	4	S20	4	S20	5	S20	4	S20	4	S20	5	S20	6								
	2	S20	2	S20	2	S20	2	S20	3	S20	3	S20	3	S20	4	S20	4	S20	5	S20	2	S20	2	S20	2	S20	2	S20	2	S20	3	S20	3	S20	4						
	3	S20	3	CQ	2	CQ	2	CQ	2	CQ	3	CQ	3	CQ	3	CQ	1	CQ	1	CQ	1	CQ	3	CQ	3	CQ	3	CQ	2	CQ	2	CQ	3	CQ	3	CQ	6				
	4	CQ	2	S20	4	S20	5	CQ	1	S20	4	CQ	1	CQ	1	CQ	4	CQ	4	S20	6	S20	4	CQ	2	CQ	2	CQ	4	CQ	4	S20	6	CQ	4	CQ	4	S20	6	CQ	4
	5	CQ	3	CQ	4	CQ	5	S20	6	CQ	1	S20	5	S20	6	S20	5	S20	6	S20	5	S20	6	S20	5	S20	6	S20	5	S20	6	CQ	5	S20	5	S20	5				
	6	CQ	1	CQ	1	CQ	1	CQ	6	CQ	4	CQ	5	CQ	6	CQ	5	CQ	6	CQ	6	CQ	4	CQ	5	CQ	6	CQ	5	CQ	6	CQ	6	CQ	6	CQ	6	S22	6		
	7	S22	1	S22	1	S22	1	S22	1	S22	1	S22	1	S22	1	S22	1	S22	2	S22	2	S22	2	S22	2	S22	2	S22	2	S22	2	S22	2	S22	3	S22	3	CQ	5		
	8	S22	3	S22	4	S22	5	S22	6	S22	4	S22	5	S22	6	S22	4	S22	5	S22	6	S22	4	S22	5	S22	6	S22	4	S22	5	S22	6	S22	4	S22	5	S22	4		
	9	S22	2	S22	2	S22	2	S22	2	S22	3	S22	3	S22	3	S22	1	S22	4	S22	5	S22	3	S22	3	S22	3	S22	2	S22	4	S22	5	S22	3	S22	4	S22	5	S22	5

S20 = 1500 HZ (TONE FREQ.)  
 CQ = 1550 HZ (TONE FREQ.)  
 S22 = 1600 HZ (TONE FREQ.)

**Table 11**

**Table 11A**

TONE GROUPS	TONE NUMBER	KEYBOARD NUMBER		FREQ (Hz)
		"MODAX" 100 "MODEN" 100	"MODEN" 36 & ALERT CENTRAL	
UPPER	0	0	0	330.5
	1	1	1	349.0
	2	2	2	368.5
	3	3	3	389.0
	4	4	4	410.8
LOWER	5	5	5	433.7
	6	6	0	457.9
	7	7	1	483.5
	8	8	2	510.5
	9	9	3	539.0
	0	0	4	330.5

TONE GROUPS	TONE NUMBER	KEYBOARD NUMBER	FREQ. (HZ)
UPPER	1	1	349.0
	2	2	368.5
	3	3	389.0
	4	4	410.8
	5	5	433.7
LOWER	6	1	457.9
	7	2	483.5
	8	3	510.5
	9	4	539.0
	0	5	330.5

**Table 12 General Electric Tone Groups**

**Table 13 Code Type Y (Quick Call)**

TONE NO.*	A SERIES (QC)		B SERIES (QC)		Z SERIES (QC)	
	REED CODE	FREQ Hz	REED CODE	FREQ Hz	REED CODE	FREQ Hz
1	DA	398.1	DB	412.1	DZ	384.6
2	EA	441.6	EB	457.1	EZ	426.6
3	FA	489.8	FB	507.0	FZ	473.2
4	GA	543.3	GB	562.3	GZ	524.8
5	HA	602.6	HB	623.7	HZ	582.1
6	JA	668.3	JB	691.8	JZ	645.7
7	KA	741.3	KB	767.4	KZ	716.7
8	LA	822.2	LB	851.1	LZ	794.3
9	MA	912.0	MB	944.1	MZ	881.0
0	CA	358.9	CB	371.5	CZ	346.7

TONE GROUP	A(GE)	B(GE)	C(GE)
TONE NUMBER	FREQ (Hz)	FREQ (Hz)	FREQ (Hz)
1	592.5	607.5	712.5
2	757.5	787.5	772.5
3	802.5	832.5	817.5
4	847.5	877.5	862.5
5	892.5	922.5	907.5
6	937.5	967.5	952.5
7	547.5	517.5	532.5
8	727.5	562.5	577.5
9	637.5	697.5	622.5
0	682.5	652.5	667.5

Table 14 "Metro-Page" 1, 2 & S Two Tone Code Plans, Prefix/Tone Group Relationships

CODE PLANS

Code Plan	B/W	C/V	D/U	E/T	F/S	G/R	H/Q	J/P	K/N	L/M	MET
Tone groups	1,2,3	1,2,4	1,2,5	1,2,6	1,3,4	1,3,5	1,3,6	1,4,5	1,4,6	1,5,6	
Tone groups	4,5,6	3,5,6	3,4,6	3,4,5	2,5,6	2,4,6	2,4,5	2,3,6	2,3,5	2,3,4	
Prefix											
00	2,4										10, 10
01	1,1	1,1	1,1	1,1	1,1	1,1	1,1	1,1	1,1	1,1	3, 10
2	2,2	2,2	2,2	2,2	1,3	1,3	1,3	1,4	1,4	1,5	10, 3
3	3,3	1,2	1,2	1,2	3,3	3,3	3,3	4,1	4,1	5,1	4, 10
4	1,2	4,4	1,5	2,1	4,4	3,1	3,1	4,4	4,4	1,6	10, 4
5	1,3	1,4	5,5	1,6	3,1	5,5	1,6	5,5	1,6	5,5	5, 10
6	2,1	2,1	2,1	6,6	1,4	1,5	6,6	1,5	6,6	6,6	10, 5
7	3,1	4,1	5,1	6,1	4,1	5,1	6,1	4,5	6,1	6,1	6, 10
8	2,3	2,4	2,5	2,6	3,4	3,5	3,6	5,4	4,6	5,6	10, 6
9	3,2	4,2	5,2	6,2	4,3	5,3	6,3	5,1	6,4	6,5	
*10	4,2										4,2
11	4,6	3,5	3,4	3,4	2,5	2,4	2,4	2,3	2,3	2,3	1,1
2	6,4	5,3	4,3	4,3	2,2	2,2	2,2	2,2	2,2	2,2	2,2
3	5,6	3,3	3,3	3,3	5,2	4,2	4,2	3,3	3,3	3,3	1,2
4	4,4	3,6	4,4	4,4	2,5	4,4	4,4	3,2	3,2	4,4	4,4
5	5,5	5,5	3,6	5,5	5,5	2,6	5,5	2,6	5,5	3,2	5,5
6	6,6	6,6	6,6	3,5	6,6	6,6	2,5	6,6	2,5	2,4	2,1
7	4,5	6,3	6,3	4,5	6,2	6,2	4,5	6,2	5,2	4,2	4,5
8	5,4	5,6	4,6	5,4	5,6	4,6	5,4	3,6	3,5	3,4	5,4
9	6,5	6,5	6,4	5,3	6,5	6,4	5,2	6,3	5,3	4,3	2,4
*20	6,6										6,6
*21	1,5										1,5
*2	5,1										5,1
*3	1,4										1,4
*4	4,1										4,1
*5	2,5										2,5
*6	5,2										5,2
7	4,5									4,5	
8	5,4									5,4	
9	1,2									1,2	
30	2,1									2,1	
*31	1,3										1,3
*2	3,1										3,1
*3	2,3										2,3
*4	3,2										3,2
*5	3,4										3,4
*6	4,3										4,3
*7	3,5										3,5
*8	5,3										5,3
*9	3,3										3,3
*40	6,1										6,1
*41	6,2										6,2
*2	6,3										6,3
*3	6,4										6,4
*4	6,5										6,5
*5	1,6										1,6
*6	2,6										2,6
*7	3,6										3,6
*8	4,6										4,6
*9	5,6										5,6
50											
51											
2											
3											
4											
5											
6											
7											
8											
9											
60	G1,G1										G1,G1
*61	G2,G1										G2,G1
*2	G2,G2										G2,G2
*3	G1,G2										G1,G2
*4	G3,G3										G3,G3
*5	G3,G1										G3,G1
*6	G3,G2										G3,G2
*7	G1,G3										G1,G3
*8	G2,G3										G2,G3
70											
71	17,18										17,18
2	17,19										17,19
3	18,17										18,17
4	19,17										19,17
5	18,19										18,19
6	19,18										19,18
7	17,17										17,17
8	18,18										18,18
9	19,19										19,19

\*Same as Metro-Page coding in most plans.  
 \*\*GE codes do not include diagonal tones.

NOTE: Some tone group combinations may appear more than once in a given plan. Code Plan ROM B/W contains code plan B for prefixes 00 through 09, prefixes 10 through 19 are used to access code plan W. All code plan ROMs contain the same information for prefixes 20 through 79, except the MET code plan. Prefixes 00 through 19 contain code plans C & V, D & U, etc., using the same format as code plan ROM B/W.

## IX. APPENDIX GROUPS 10 & 11

Since September, 1978, tone groups 10 and 11 have been available to provide additional code capacity for two-tone paging. These tone groups contain 20 paging tones between 1472.9 Hz and 2468.2 Hz. These tone groups are standard on small paging encoders (100 calls or less), or can be ordered on an SP basis for terminals with more than 100 call capability. Refer to Table 15 for tone frequencies and Table 16 for a list of encoders and terminals using groups 10 and 11. Tone groups 10 and 11 can be used in their entirety or paired with standard groups, e.g., 10/1, 10/2, 11/1, 11/2, 1/10, 2/10, 1/11, 2/11, 11/10, 10/11, etc.

When should groups 10 and 11 be used?

- A. When large paging systems are running out of codes.
- B. When new customers on multi-user channels need relief from code conflicts.
- C. When existing groups are not compatible with competitive code plans.

Tone groups 10 and 11 should NOT be used, except for one of the previously mentioned situations, or when a similar condition arises.

Tone groups 10 and 11 place limitations on both two-tone pagers and paging terminals. Some pagers can experience "alert tone lock-up" when the tone B frequency is between 1733.7 Hz and 2212.2 Hz, however, other pager models work well with all tones. All current paging terminals are capable of generating tone groups 10 and 11, however, if used with tone remote control base stations, these high frequency tones may be notched out.

Contact your Area System Engineer before ordering pagers with group 10 or 11 codes, or when a tone remote control base station is to be used.

In summary, tone groups 10 and 11 are for use in special circumstances, and very careful control of their use is required.

TABLE 15

	TONE GROUP 10		TONE GROUP 11	
	CODE	FREQ (Hz)	CODE	FREQ (Hz)
TONE NUMBER	0	170	200*	1930.2
	1	171	201*	1989.0
	2	172	202*	2043.8
	3	173	203*	2094.5
	4	174	204*	2155.6
	5	175	205*	2212.2
	6	176*	206	2271.7
	7	177*	207	2334.6
	8	178*	208	2401.0
	9	179*	209	2468.2

\* USE ONLY AS "TONE A" DO NOT USE AS "TONE B" OF PAGER CODE. ON PAGERS WITH "ALERT TONE LOCK-UP" RESTRICTIONS.

TABLE 16

TERMINAL / ENCODER	GROUPS 10 & 11 STD. OPT.	GROUPS 10 & 11 S.P. OPT.	REMARKS
"METRO-PAGE" 10/100	---	YES	
"METRO-PAGE" 1,2,& S	---	YES	REQUIRES NLN5139A SYNTHESIZER BD.
"MODAX" 500	---	YES	REQUIRES NLN5140A CODING TIMER SYNTHESIZER BD.
"MODEN" 900	---	YES	
"MODAX" 100	YES	---	
"MODEN" 36 & 100	YES	---	
ALERT CENTRAL	YES	---	



**MOTOROLA** *Communications and Electronics, Inc.*

A Subsidiary of Motorola Inc.

1301 E. Algonquin Road, Schaumburg, Illinois 60172 • (312) 397-1000